

Water scarcity risks mitigated or aggravated by the inter-regional electricity transmission across China

Chunyan Wang^a, Ranran Wang^b, Edgar Hertwich^c, Yi Liu^{a,*}, Fan Tong^d

^a School of Environment, Tsinghua University, Beijing, China

^b Faculty of Engineering Technology, University of Twente, Enschede, the Netherlands

^c School of Forestry and Environmental Science, Yale University, New Haven, USA

^d Department of Global Ecology, Carnegie Institution for Science, Stanford University, CA, United States

HIGHLIGHTS

- The water scarcity risks propagated by inter-basin electricity transmission were unequally-distributed.
- Around 10% of the national population would be potentially exposed to higher water scarcity level.
- Thermal power significantly aggravated the water scarcity, especially in southern part of China.

ARTICLE INFO

Keywords:

Inter-grid electricity transmission
Water scarcity basin
(Highly-) affected population
Benefited population

ABSTRACT

Traditionally, around 34–38% of China's population resides in places experiencing high water scarcity for at least one month a year. However, the risk of water scarcity may be further exacerbated by inter-regional electricity transmission, due to the mismatch between the electricity-receiving population living in water-abundant areas and the water scarcity experienced in the electricity-exporting region. Using detailed thermal/hydro- power plants data and water scarcity index at the water basin scale, this study systematically quantified this additional water scarcity risk across China. The affected population, i.e. those living in basins under lower water scarcity but needing electricity generated in basins with higher water scarcity, was estimated to be 134 million, or 10% of the total population in China. Among this, over 60 million people were considered as highly-affected population (i.e. people who live in no/low stress basins rely on electricity generated in severe/extreme scarcity basins), the majority of whom lived in Southern China. This leads to a 12% increase in water-stressed population if the proposed transmission projects were implemented. On the other hand, more people, i.e., 285 million, would benefit from the inter-regional electricity transmissions. They relied on the electricity generated from basins under lower water scarcity. It is found that intra-grid's thermal electricity transmission was less effective in mitigating the water scarcity than the hydroelectricity. It determined that the southern part of China faced worse environmental performance in coordinating its water endowment with the electricity generation because of its use of electricity from water stressed basins rather than from the water sufficient basins.

1. Introduction

The economy and human welfare are increasingly threatened by water scarcity in many places of the world [1–3]. Over the past decades, the population facing water scarcity increased from 14% to 58% worldwide [2]. Meanwhile, a growing body of empirical studies highlighted that interregional trade of products and services may effectively reduce water consumption and thus water scarcity levels at various scales. That is, a region's water demand and water scarcity risk may be

mitigated by importing virtual water, i.e. water embodied in products and goods traded from other regions [4,5]. Reduced water consumption and improved scarcity level at the global scale have been attributed to the increased production efficiency achieved through sectoral specialization and international trade [4,6,7]

However, both the risks of water scarcity and the mitigation effects of interregional trade were assessed from a territorial perspective. That is, water scarcity of a region scales up (down) as the region's water demand increases (decreases), e.g. due to virtual water trade. Most

* Corresponding author.

E-mail address: yi.liu@tsinghua.edu.cn (Y. Liu).

<https://doi.org/10.1016/j.apenergy.2019.01.120>

Received 4 May 2018; Received in revised form 22 August 2018; Accepted 17 January 2019

Available online 22 January 2019

0306-2619/ © 2019 Elsevier Ltd. All rights reserved.

recently, these propositions are challenged for neglecting the potential risks experienced in the exporting regions, such as water scarcity, political instability, regulatory changes, and natural disasters, which could be propagated to the importing regions along with the commodities being traded [8]. These impacts are particularly pertinent if production of the commodity features high specialization, regional concentration, and low substitutability, such as electricity [9].

As such, this study investigates how inter-regional electricity transmission, i.e. the interregional trade of electricity, affects the risks of water scarcity across mainland China. This investigation is especially pertinent considering China's critical development needs and emerging constraints related to water, energy, and their interactions. From the territorial perspective, 443–525 million people or 34–38% of the total population in China live with high water scarcity [10–12], partially due to the highly variable water availability across time and space [1,13]. To meet the growing energy consumption [14,15], electricity generation facilities play a critical role in water consumption and thus scarcity. Electricity generation is the largest direct water consumer among all industries, accounting for 37% of the country's industrial freshwater consumption in 2014 [16]. Virtual water embodied in electricity accounted for 11% of the total virtual water trade within China [17]. Considering the net physical water transfer and virtual water flows associated with the inter-provincial trade of all products, water scarcity in 12 provinces was mitigated as net importers while 11 already water-stressed provinces were further worsened as net exporters [18].

Yet, how water scarcity risks are propagated from electricity exporters to importers through the ever-growing electricity grid in China is unknown. The electricity grid system in mainland China is comprised by 7 sub-regional grids, which are operated by two national-level state-owned enterprises and one local state-owned enterprise [19,20]. Previously, studies identified the mismatch between electricity generation and water availability in China at province level [19,21–24]. The top three virtual scarce water exporters through electricity are all water-stressed provinces; the electricity transmission lines currently under construction will likely enlarge the scale of scarce water outflows from these regions [19]. Therefore, people living in water-abundant areas could be exposed to higher water scarcity risks due to their reliance on the electricity transmitted from these water-scarce regions. That is, more than the 34–38% of the national total population (the traditional understanding of water scarcity) [10–12] could be threatened by water scarcity. However, there might also cause that consumers living in water-stressed regions may benefit from using electricity transmitted from water-abundant regions. Currently, there is a knowledge gap of the uncounted water scarcity threatened or benefited population due to the electricity transmission. Moreover, considering the great spatial differentiations of the population and water scarcity, high resolution analysis is urgently needed. Further, distinguishing the water scarcity mitigation or aggravation brought by the thermal power from the hydropower (the major electricity generation types) would shed lights on an integrated management of water and energy.

The rest of the paper is organized as follows. In the next section, we describe the method and data sources of our analysis. At the basin scale, we model the flows of electricity and virtual water, as well as the direct and propagated water scarcity risks. Our model is based on up-to-date, high-resolution datasets of annual anthropogenic water use in 1630 water basins (97% of the land area in mainland China) and electricity generation of 782 power plants. Both thermoelectric (coal-fired power, gas-fired power, nuclear, etc.) and hydroelectric power plants are considered in our model. Together, they accounted for about 80% of the electricity generation in China in 2014 [25]. Since detailed information on electricity transmission is unavailable, we model the electricity transmission between basins based on assumptions detailed below. In Section III, we present our results, discussing the water scarcity effects induced by electricity transmission across mainland China, as well as the different effects of thermal electricity or hydroelectricity. In Section IV, we conclude the paper by presenting the most relevant insights for

infrastructure planning, water scarcity mitigation in China, and directions for future research.

2. Methodology

At the basin scale, we model the generation, consumption, and transmission of electricity, the virtual water embodied in electricity transmission, as well as the direct and propagated water scarcity risks across mainland China. Based on the basin delineations in [26], 1630 basins covering 97% of the land area in mainland China are included in our model. Fig. 1 provides a schematic overview of the modeling process and key variables, using a simple case of three basins within the same transmission grid.

Based on the relative comparison between electricity generation (EG) and electricity consumption (EC) in each basin, we classify three possible outcomes: (1) $EG = EC$ (e.g. Basin 1 in Fig. 1), defined as an electricity-balanced basin; (2) $EG < EC$ (e.g. Basin 2 in Fig. 1), defined as an electricity-deficient basin; and (3) $EG > EC$ (e.g. Basin 3 in Fig. 1), defined as an electricity-surplus basin. Accordingly, electricity surplus of a basin is defined as the extra electricity after satisfying the electricity consumption in a surplus basin (e.g. $EG - EC$ in Basin 3). The electricity surplus is transmitted to electricity-deficient basins (e.g. Basin 2). In other words, electricity transmission redistributes electricity between electricity-deficient basins and electricity-surplus basins to some extent. The cross-region transmission (which Basin 2 imports from Basin 1, then exports to Basin 3) is not accounted in this study, due to the fact that less than 1% of the total electricity generation is cross-region transmitted [27].

Depending on the direct water scarcity level of the electricity-deficient, importing basins relative to that of the electricity-surplus, exporting basins (i.e., $WS_{deficient}$ vs $WS_{surplus}$), electricity transmission may alter the water scarcity risks conventionally assessed for the electricity-deficient basins, specifically:

Water scarcity risk is aggravated ($WS_{deficient} < WS_{surplus}$): people are indirectly exposed to higher water scarcity levels since (a fraction of) the electricity they use is generated in basins with higher scarcity levels; we refer to those people as *affected population*.

Water scarcity risk is mitigated ($WS_{deficient} > WS_{surplus}$): people are indirectly exposed to lower water scarcity levels since (a fraction of) the electricity they use is generated in basins with lower water scarcity; we refer to those people as *benefited population*.

2.1. Modeling electricity transmission

2.1.1. Electricity generation at the plant and basin level

We collect plant-level electricity generation data from a variety of sources and harmonize them into a comprehensive and coherent dataset. The sources provide electricity generation in 2014 (the latest data available) by: (1) 1048 large coal-fired power plants with installed capacity > 100 MW (a total net electricity generation of 2253 TWh) [28]; (2) 97 Circulating-Fluidized-Bed-Boiler (CFB)¹ units with installed capacity > 25 MW (a total net electricity generation of 103 TWh) [29]; (3) 314 thermoelectric power plants with installed capacity > 100 MW (a total net electricity generation of 2377 TWh) [30]; and (4) 217 hydropower plants with installed capacity > 50 MW (a total electricity generation of 661 TWh) [30]. We merge the CFB units to the power plants they belong to. If the same power plant is included in more than one data sources, we only preserve the one with the highest estimation of electricity generation. This results in 565 unique thermal power plants in total. The thermal power plants and the hydropower plants included in our study accounted for more than 76% and 62% of the total thermal power and hydropower generated in China in 2014,

¹ Circulating-Fluidized-Bed-Boiler (CFB) is a relatively new and developing technology for coal combustion to achieve lower emission of pollutants.

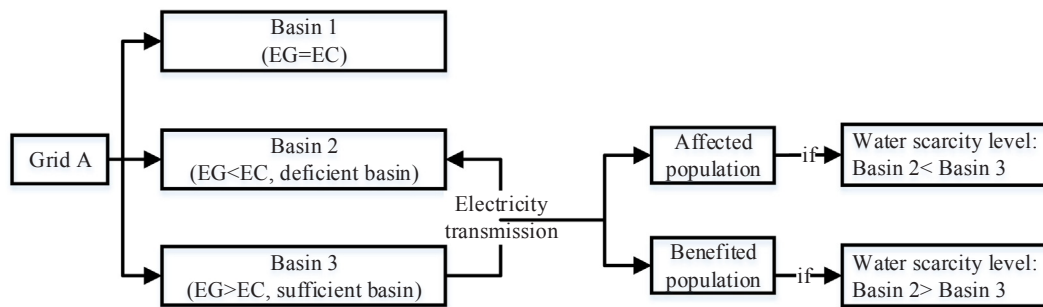

Fig. 1. A schematic overview of the modeling processes. Notes: EG represents electricity generation, EC represents electricity consumption.

respectively [25]. We then geocode the power plants using Google Earth [31] and Baidu API [32] and spatially match them to basins in a Geographic Information System (ArcGIS) [33]. The compiled dataset consists of each power plant's name, geographic location, installed capacity, and generation and cooling type (see Supporting Information (SI) Table S1).

2.1.2. Electricity consumption at the basin level

We obtain annual electricity consumption in 2014 at the province level from the *Energy Statistical Yearbook* [34] and the population data of mainland China from *National Bureau of Statistics* [35] at the county and province levels in 2010 (which was the latest national census). By spatially matching the areas of the 2751 counties to those of the 1630 basins in ArcGIS, we obtain the population estimation at the basin level. For each province, we obtain a unique electricity consumption level, i.e. per capita electricity consumption, by dividing the annual electricity consumption and population of that province. After spatially matching the areas of the provinces with the areas of the basins, we multiply the basin-level population with the corresponding province-level per capita electricity consumption to obtain the electricity consumption at the basin level.

2.1.3. Electricity generation within each grid

The electricity grids are classified into 7 sub-regional grids (i.e. Northeast China, North China, Northwest China, Central China, East China, South China, and Tibet, see SI, Fig. S1). We spatially match the areas of the basins with the areas of the sub-regional grids in the ArcGIS to determine which grid the basin belongs to (see SI Fig. S2). If a basin falls into more than one grids, we place it with the grid where the geometric center of that basin falls. We obtain the electricity generation of each sub-regional grid by adding up the basin-level electricity generation within the same grid. In the following analysis, we exclude Tibet due the data availability issues. Therefore, only six sub-regional grids are included.

2.1.4. Electricity balance and transmission within each grid

Constrained by data availability, our dataset only covers 80% of the total electricity generation in mainland China. To our best knowledge, more comprehensive plant-level electricity generation dataset or detailed electricity transmission data are not available. We thus make two assumptions:

Assumption 1: Within each of six sub-regional grids, the electricity generation accounted in our dataset equals electricity consumption. Thus, the basin-level electricity consumption of each grid is adjusted by multiplying the ratio of total electricity generation accounted to total electricity consumption reported for each grid.

Assumption 2: Within each grid, electricity surplus from surplus basins is well mixed and transmitted to deficient basins (as illustrated in Fig. 1).

Inter-grid electricity transmission in China is minimal, i.e. 272 billion kWh, or 6% of the total electricity generation in 2011 [19].

According to Qu et al. [27], the difference between the real grid's electricity consumption and generation is less than $\pm 9\%$ [27]. Besides, there are complex political, economic, and social factors that govern intra/inter-grid transmissions [36,37], which are beyond the scope of our study. Due to the reasons aforementioned, the **Assumption 1** is made. The implications of **Assumption 2** were tested in [9], which modeled monthly basin-level electricity transmission within regional grids in the United States. Their results were found to be robust to the assumption.

2.2. Quantifying water scarcity at the basin level

Water availability to population ratio (AP) and *water withdrawal to availability ratio (WTA)* [2] are two widely-adopted water scarcity indicators (WSI) [38]. Considering the growing importance of inter-basin water transfers in sustaining anthropogenic water needs, especially in the virtual form, we quantify the water scarcity directly experienced at the basin level using the *WTA*, see Eq. (1). We include the AP-based results in the SI.

$$WTA = \frac{WW_i}{WA_i} \quad (1)$$

where WW_i : water withdrawal of basin i , m^3/yr ; WA_i : water availability of basin i , m^3/yr .

We use WW_i and WA_i estimated in [26]. Consistent with previous studies [10,18,39], the direct water scarcity level of basin i is categorized as “no scarcity”, “low scarcity”, “moderate scarcity”, “severe scarcity”, or “extreme scarcity” depending on the value of WTA_i in the range of 0–0.1, 0.1–0.2, 0.2–0.4, 0.4–1.0, or > 1.0 , respectively.

2.3. Quantifying population affected or benefited from electricity transmission

2.3.1. Affected population

We use *affected population* and *benefited population* to quantify the aggravated or mitigated water scarcity risks owing to electricity transmission. Intuitively, the *affected population* (*benefited population*) are those who live in electricity-deficient basins with lower (higher) direct water scarcity but consume electricity generated in basins with higher (lower) direct water scarcity. Basin i is electricity-deficient if its electricity consumption (EC_i) is larger than its electricity generation (EG_i), and we quantify the electricity deficiency rate (Def_i) as:

$$Def_i = (EC_i - EG_i)/EC_i \quad (2)$$

According to **Assumption 2** in Section 2.1.4, within each grid j , electricity outflows from the surplus basins are well mixed and transmitted to the electricity-deficient basins. For the electricity-deficient basin i with water scarcity level n , if it is receiving electricity from electricity-sufficient basin k with water scarcity level m higher than n ($EG_{k,m} - EC_{k,m}$), then this electricity outflow is defined as the water-stressed electricity outflow. By summarizing the water-stressed

electricity outflows within the grid j , the total water-stressed electricity transmitted to basin i is be calculated ($\sum (EG_{k,m} - EC_{k,m})$). Dividing the total water-stressed electricity outflow by the total the electricity outflows of grid j (i.e. the sum of the electricity surplus from basin h whatever the scarcity level is) ($EG_h - EC_h$), we will get the ration ($Out_{i,j,n}$), which is the fraction of electricity outflows generated in higher stressed basins transmitting the basin i (see Eq. (3)).

$$Out_{i,j,n} = \sum (EG_{k,m} - EC_{k,m}) / \sum (EG_h - EC_h) \quad (3)$$

Identifying the thermal electricity from the surplus electricity would result in the thermal electricity outflow rate ($Out_{thermal,i,j,n}$) (see Eq. (4)).

$$Out_{thermal,i,j,n} = \sum (EG_{thermal,k,m} - EC_{thermal,k,m}) / \sum (EG_h - EC_h) \quad (4)$$

Therefore, the affected population of grid j (AP_j) could be estimated based on the population of deficient basin i (Pop_i), deficiency rate (Def_i) and electricity outflow rate ($Out_{i,j,n}$) (see Eq. (5)).

$$AP_j = \sum Pop_i \times Def_i \times Out_{i,j,n} \quad (5)$$

The affected population because of thermal electricity transmission of grid j ($AP_{thermal,j}$) could be estimated based on the population of deficient basin i (Pop_i), deficiency rate (Def_i) and thermal electricity outflow rate ($Out_{thermal,i,j,n}$) (see Eq. (6)).

$$AP_{thermal,j} = \sum Pop_i \times Def_i \times Out_{thermal,i,j,n} \quad (6)$$

Among the affected population, the highly-affected population are those living in basins under no/low direct water scarcity (water scarcity level q) but relying on electricity transmitted from surplus basin with severe scarcity/extreme scarcity level p ($EG_{s,k,p} - EC_{s,k,p}$). The electricity outflows ($Out_{s,i,j,q}$) would then be adjusted as Eq. (7):

$$Out_{s,i,j,q} = \sum (EG_{s,k,p} - EC_{s,k,p}) / \sum (EG_h - EC_h) \quad (7)$$

The highly affected population (HAP_j) would be calculated as Eq. (8).

$$HAP_j = \sum Pop_i \times Def_i \times Out_{s,i,j,q} \quad (8)$$

Similarly, the adjusted thermal electricity outflows ($Out_{thermal,s,i,j,q}$) would be calculated as Eq. (9):

$$Out_{thermal,s,i,j,q} = \sum (EG_{thermal,s,k,p} - EC_{thermal,s,k,p}) / \sum (EG_h - EC_h) \quad (9)$$

The highly-affected population because of the thermal electricity transmission ($HAP_{thermal,j}$) was estimated Eq. (10).

$$HAP_{thermal,j} = \sum Pop_i \times Def_i \times Out_{thermal,s,i,j,q} \quad (10)$$

2.3.2. Benefited population

The benefited population are those who live in electricity-deficient basins with higher water scarcity and consume electricity generated in basins with lower water scarcity. Benefited population by thermal power are estimated by identifying the transmitted electricity generated from basins with lower water scarcity level.

The electricity outflow rate of grid j ($Out_{i,j,m}$) is calculated based on the electricity surplus basin k with lower water scarcity level n ($EG_{k,n} - EC_{k,n}$) than basin i divided by the electricity surplus from basin h whatever the scarcity level is ($EG_h - EC_h$) (see Eq. (11)).

$$Out'_{j,m} = \sum (EG_{k,n} - EC_{k,n}) / \sum (EG_h - EC_h) \quad (11)$$

Therefore, the benefited population of grid j (BP_j) could be estimated based on the population of deficient basin i (Pop_i), deficiency rate (Def_i) and electricity outflow rate ($Out_{i,j,m}$) (see Eq. (12)).

$$BP_j = \sum Pop_i \times Def_i \times Out'_{i,j,m} \quad (12)$$

Identifying the thermal electricity from the surplus electricity would denote the thermal electricity outflow rate ($Out'_{thermal,i,j,m}$) (see Eq. (13)).

$$Out'_{thermal,i,j,m} = \sum (EG_{thermal,k,n} - EC_{thermal,k,n}) / \sum (EG_h - EC_h) \quad (13)$$

The benefited population because of thermal electricity transmission of grid j ($BP_{thermal,j}$) could be estimated based on the population of deficient basin i (Pop_i), deficiency rate (Def_i) and thermal electricity outflow rate ($Out'_{thermal,i,j,n}$) (see Eq. (14)).

$$BP_{thermal,j} = \sum Pop_i \times Def_i \times Out'_{thermal,i,j,n} \quad (14)$$

3. Results

3.1. Regional heterogeneity in the water scarcity of power generation

Annual electricity generation in 565 power plants and water scarcity of 1630 basins across mainland China are mapped in SI Fig. S3. In 2014, around 63% thermal power plants were located in more water stressed basins ($WSI \geq 0.2$). This mismatch between thermal electricity generation, especially coal-fired power plants, and water availability may reflect the high environmental pressures in highly populated areas and also be a result of political (e.g. energy self-sufficiency [40]) and/or economic (e.g. the “West to East Electricity Transmission” project [41]) decision making.

We find socioeconomic activities are more susceptible to the threat of drought on power supply within electrical grids that are more water-stressed, i.e. in the North China, Northeast China, and South China grids. As shown in Fig. 2, within those grids, 99.7%, 84%, and 8% of population lived in more water stressed basins ($WSI \geq 0.2$), while 100%, 89%, and 16% of electricity was supplied from there, respectively. Considering the electricity transmission across basin boundaries, a majority of the most water stressed basins ($WSI > 1$) in the North China, Northeast China, and Northwest China grids were net power provider, with 70%, 26%, 52% net electricity inflows, respectively.

In contrast, in the East China grid, 15% of population lived in basins under extreme water scarcity, while 9% less of the electricity was generated there; 20% of population lived in basins under no water stress, while 5% of more of the electricity was generated there.

For now, the conclusion of the Central China grid is mixed. For the basins with extreme water scarcity, it took up to 16% of the population and 24% of the electricity generation. This indicates that it aggravated its water scarcity. However, the population of the no water stressed basins was 33%, while the electricity generation was 55%. This indicates that it was trying to mitigate the water scarcity problem.

The thermal electricity and hydroelectricity outflows of each grid are illustrated by the filled bars in Fig. 3. It should be noted that percentages of the thermal electricity outflows from more water stressed basins ($WTA \geq 0.2$) were greater than those of the thermal electricity generation from water stressed basins (i.e. the dashed blank bars in red in Fig. 3, set as the benchmarks) in the East China and South China grids, i.e. 68% > 67% and 22% > 16%. This indicates that these two grids were consuming their scant water resource to generate and transmit thermal electricity to water sufficient basins.

However, the Central China and South China grids, whose hydroelectricity generation accounted for nearly 40% (see Fig. 3 and SI Table S3), were experiencing completely different electricity transmission patterns. Different from the South China grid, Central China grid relieved or at least not to worsen its own water scarcity problem. This could be inferred by the two facts: (1) it had smaller portion of transmitted thermal electricity from more water stressed basins ($WTA \geq 0.2$) (i.e. 15%) than its own benchmark (i.e. 28%); (2) it has greater portion of transmitted hydroelectricity than that of the generated hydroelectricity, which was regarded to be less water intensive than thermal power [42].



Fig. 2. Relative share of electricity/population among all basins of each grid. Notes: (a): The gray bars represent the electricity generation structure, which was the portion of electricity generated in the basins with given level of water scarcity to the total electricity generation of each grid; (b): The red bars represent the electricity demand structure, which was the portion of electricity consumed in the basins with given level of water scarcity to the total electricity consumption (generation) of each grid; (c): The black bars represent the population structure, which was the portion of the population who lived in same level of water scarcity basin to the total population of that grid; (d): The green dots represent the electricity transmitted from the basins with given level of water scarcity to the total electricity transmission of each grid; (e): The red dots represent the deficient electricity (i.e. electricity gap) of the basins with given level of water scarcity to the total electricity transmission of each grid. (For interpretation of the references to colour in this figure legend, the reader is referred to the web version of this article.)

3.2. Large power plants aggravated the water scarcity

An analysis focused on the large power plants helps reveal the major water scarcity implications of electricity generation and transmission. In 2014, 153 (27%) thermal power plants generated around 50% of the total thermal electricity. These plants are concentrated in severely- and extremely- stressed basins, especially in the North China and Northwest China grids (detailed in SI Table S10). Around 70% of the total hydroelectricity was generated by 28 hydropower plants (13% of the hydropower plants) in 2014. These large hydropower plants are located in the Central China, South China, Northwest China grids (see Fig. 4, detailed in SI Table S11). The largest and second largest dams, i.e. the Three Gorges Dam and Xiluodu Dam, are located in no stress basins in the Central China and South China grids, respectively, contributing to 15% and 8% of hydro electricity generation. It should be noted that a large hydropower plant, Xiaolangdi Dam with 1% of hydro-electricity generation, is located in a basin with extreme scarcity in the Central China grid. These large hydropower plants in the Central China and South China grids accounted for 77% and 76% of the grids' total hydroelectricity generation.

Naturally, larger power plants are more likely to transmit electricity beyond the basin boundary. There were 147 (81%) large power plants located in the electricity sufficient basins, among which 93 large power plants were located in the more water stressed basins ($WTA \geq 0.2$). Among the 58%, 83%, and 47% of the large thermal power plants located in the electricity sufficient basins of the East China, Central China, and South China grids were from the more water stressed basins, respectively. It could lead to the aforementioned fact, that the East China and South China grids aggravated their water scarcity problems by consuming the scant water to generate electricity for the purpose of supporting the socioeconomic activities of the water abundant basins via electricity transmission.

However, the distribution of the large thermal power plants of the Central China grid tells a different story from the distribution of the total electricity outflows of that grid (see Figs. 2 and 3). This might be because that the large thermal power plants only accounted for the 31% of the total thermal electricity generation of the Central China grid. The distribution of these power plants would be a good representative of the total thermal electricity outflows. The large power plants would have greater influence on the water scarcity due to the high water-intensity

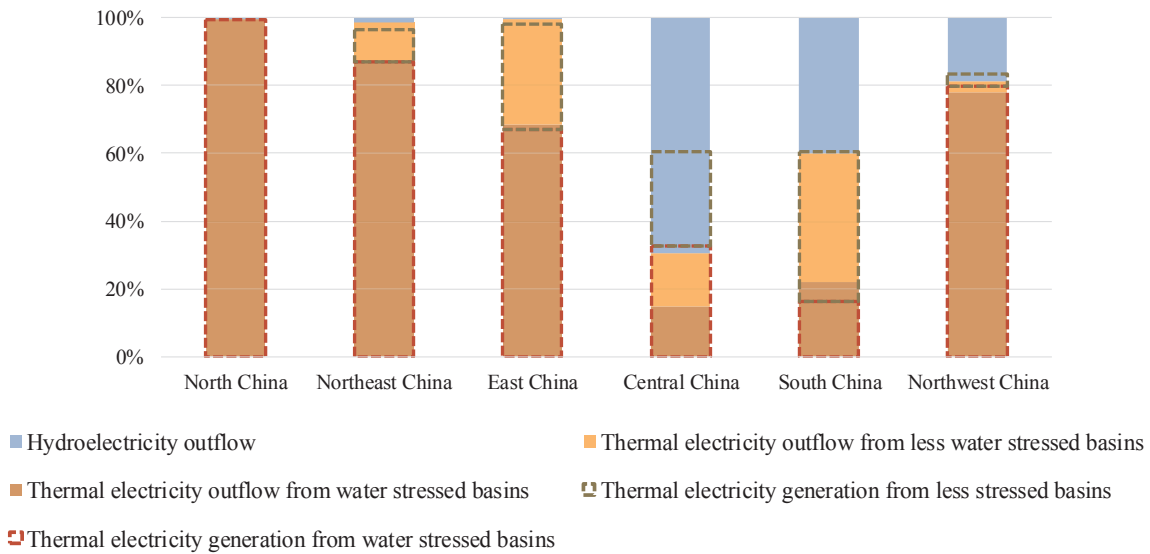

Fig. 3. Electricity outflows of each grid. Notes: (a): The filled bar charts are the electricity outflows of each grid. The dark orange bars represent the thermal electricity outflows generated from more water stressed basins ($WTA \geq 0.2$), and the light orange bars represent the thermal electricity outflows generated from less water stressed basins ($WTA < 0.2$), and the blue bars represent the hydroelectricity outflows; (b): The blanked dashed bar charts are the electricity generation of each grid regardless that whether the electricity is consumed locally or transmitted. The red dashed bars represent the thermal electricity generated from the more water stressed basins ($WTA \geq 0.2$). The brown dashed bars represent the thermal electricity generated from the less water stressed basins ($WTA < 0.2$). These two dashed bars are used as the benchmarks.

requirement.

As the North China, Northeast China and Northwest China grids barely have basins with less water scarcity, no further discussions would be made about the spatial distribution of the large power plants of these three grids in this section.

3.3. Population relying on electricity transmission

Within each electrical grid, an average of 106 (39%), 62 (51%), 118 (44%), 150 (49%), 115 (47%), and 59 (62%) million people rely on

electricity transmitted from other basins, respectively, in the North China, Northeast China, East China, Central China, South China, and Northwest China grids.

3.3.1. Affected population

Given the concept of affected people, there were around 134 million people using electricity generated in basins with higher level of water scarcity, accounting for 10% of the national population (see Table 1). 45 million of those affected population were from the South China grid. In comparison, this additional water scarcity threat caused by

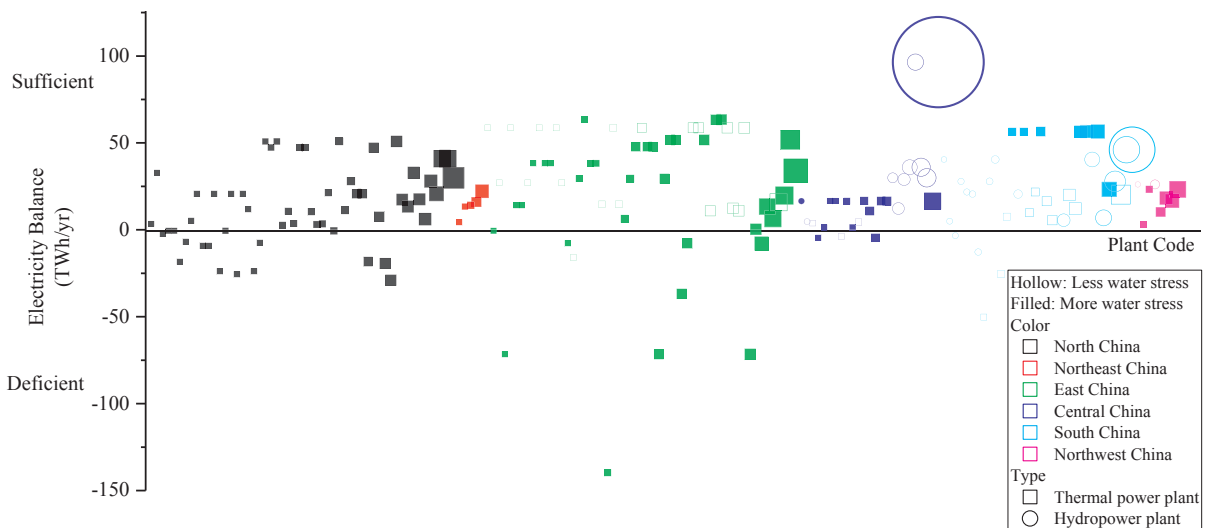

Fig. 4. Large power plants. Notes: (a): The criteria for defining large thermal power plants is that generating 50% of the total thermal electricity. This results in 27% of the thermal power plants, generating a minimum of 6.8 TWh/yr; (b): The criteria for defining large hydropower plants is that these plants should be among the 13% of the plants that generate 70% of the total hydroelectricity, among which the smallest thermal power plant was 5.8 TWh/yr; (c): The colors represent different grids; (d): The Y-axis represents the electricity balance of each basin. A positive number means generation was larger than consumption, in other words, these basins would transmit their electricity to other basins. A negative number means generation was smaller than consumption. (e): Each dot represents one power plant. The box dots refer to the thermal power plants, and the circle dots refer to hydropower plants; (f): The size of the circle or box dots represents the electricity generation of the power plants; (g): The hollow dot represents that the large power plant locates in the less water stressed basins ($WTA < 0.2$), and the filled dot represents that the large power plant locates in the more water stressed basins ($WTA \geq 0.2$).

Table 1
Population relying on electricity transmission.

	Population relying on total electricity		Population relying on thermal electricity	
	Affected population (%) (million)	Benefited population (%) (million)	Affected population (%) (million)	Benefited population (%) (million)
North China	2% (5)	11% (31)	2% (5)	11% (30)
Northeast China	15% (17)	24% (29)	14% (17)	24% (28)
East China	10% (24)	24% (58)	10% (24)	24% (57)
Central China	7% (23)	25% (87)	6% (22)	7% (25)
South China	18% (45)	10% (24)	15% (37)	4% (9)
Northwest China	22% (21)	22% (21)	21% (20)	13% (12)

Notes: (a): The percentage number is the relative value of the affected (benefited) population to the grid's total population; (b): The number in brackets is the absolute value of the affected (benefited) population.

electricity transmission was less severe in the drought-prone North and East China grids. In the South China grid, the implications of hydropower are more considerable, which lead to nearly 9 million less population being exposed by the water scarcity due to the electricity transmission.

3.3.2. Highly-affected population

Nearly half of the affected population were highly-affected, which were people living in basins of minimal direct water scarcity ($WSI < 0.2$) but consuming electricity generated in highly-stressed basins ($WSI \geq 0.4$). As such, 61 million people or 4.6% of total population were indirectly exposed to high water scarcity threat through electricity supply. This number accounted for 12% of the population living with minimal direct water scarcity and about 9% of the population affected by high water scarcity directly (see Table 2). The majority of the highly-affected people (59%) were located in the South and Central China grids (see Fig. 5). In the North China grid, up to 81% of the population living with minimal direct water scarcity were susceptible to impact of high water scarcity in electricity producing basins.

The absolute value of the difference between the affected and highly-affected population was 73 million at the national level (see Tables 1 and 2). At the grid level, the East China, Central China, South China and Northwest China grids showed significant differences between these two accounts, i.e. 15, 10, 22, and 14 million, respectively. This means the highly-affected population would be 63%, 43%, 49%, and 67% less than the affected population. In other words, a great amount of population would not be exposed to the serious water scarcity problems. Therefore, the larger this percentage was, the better adaption the grid has been made. For the South China grid, the decrease ratio was quite low. This was consistent with the previous discussion about the performances of these two grids from the view of electricity/population structure, electricity transmission, and large power plants' distribution. For the Central China grid, although 84% of the electricity outflows were from no water stress basins, there still remained 15% of

Table 2
Distribution of highly-affected population among 6 grids.

	Highly-affected population because of electricity transmission (million)	Highly-affected population because of thermal electricity transmission (million)	Population living in basins with low/no scarcity (million)	Population living in basins with severe/extreme scarcity (million)
North China	1	1	1	262
Northeast China	8	8	19	83
East China	9	9	68	134
Central China	13	13	195	100
South China	23	23	225	16
Northwest China	7	7	16	67
Total	61	60	528	662

electricity outflows generated in the basins with extreme water scarcity (see Fig. 2). This was in agreement with the discussion of the large power plants' contribution to the water scarcity in previous section. Moreover, 56% of the deficient electricity (i.e. electricity gap) were demanded by the population from no/low water stressed basins (the basis of calculating the highly-affected population). However, the North China grid had the largest decrease ratio, i.e. 80% (from 5 million to 1 million). This is mainly due to the fact that only 0.3% of this grid's population lived in the no/low stressed basins.

Comparing the highly-affected population by electricity transmission and thermal electricity transmission, it was clear that almost all the basins had the same level of highly-affected population, except the one basin in Central China grid (see SI Fig. S11). This suggests that the hydropower transmission did not have significant influence on the highly-affected population at the basin level. This was consistent with the results as shown in Fig. 3 that most of the surplus electricity were dominated by thermal power, except for the Central China and South China grids. However, as the hydroelectricity outflows were mainly generated in the basins with less water scarcity ($WTA < 0.2$), this would not contribute to the highly-affected population accounting.

3.3.3. Benefited population

In total, 249 million or 161 million people benefited from the electricity or thermal electricity transmission, by using electricity generated in basins of lower water scarcity level (see Table 1). These estimates are much higher than those of the (highly-) affected population, especially in the drought-prone North, Northeast, East, and Central China grids. Our results indicate that the current electricity generation and transmission pattern in these grids had overall mitigated the impacts of water scarcity. However, for the South China grid, the affected population was larger than the benefited population. This is because that the South China grid was relatively water abundant, which could lead to the population living in water stressed basins (the basis of calculating the benefited population) far less than the population living in water sufficient basins (the basis of calculating the affected population) (see Fig. 6 and SI Fig. S12). For the Northwest China grid, the affected population and benefited population were similar.

Comparing the estimates of benefited population due to total electricity transmission vs. thermal electricity transmission only, we find hydropower made a considerable contribution to the benefited population in the Central, South, and Northwest China grids (see Fig. 6 and SI Fig. S12). This could be explained by the fact hydroelectricity played a significant role in the electricity outflows in these grids (see Fig. 3). Take the Central China grid, which had the largest difference between the two accounts, as an example. The benefited population would decrease 71% (i.e. 62 million) when only accounting for thermal electricity. More importantly, this difference was result of the large hydropower plants (especially, the Three Gorges Dam) located in the basins with minimal water scarcity.

Further, 109 million people living with considerable direct water scarcity ($WSI \geq 0.2$) relied on electricity generated in the basins with minimal scarcity. This means that 44% of the benefited population would be unlikely to suffer from water scarcity thanks to the electricity

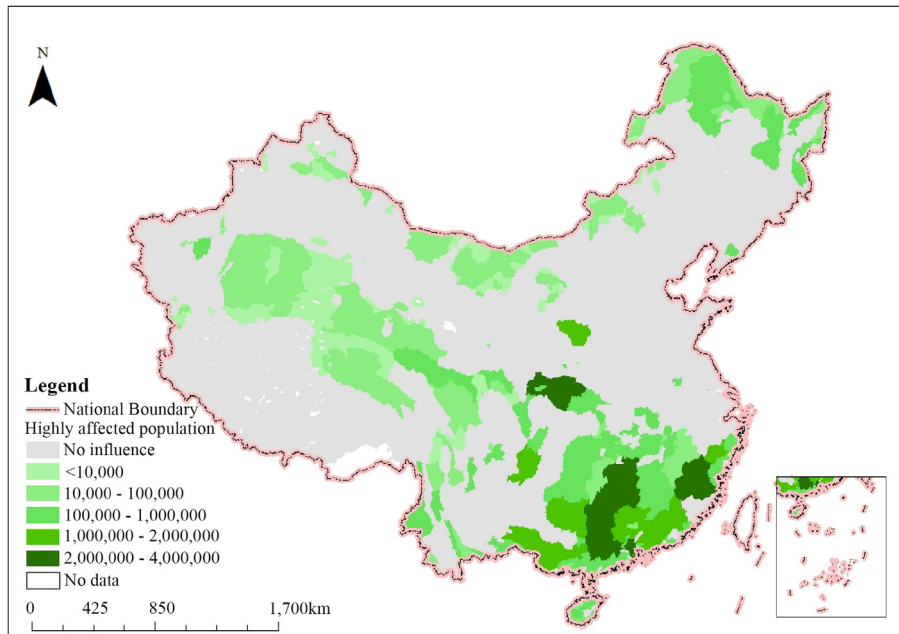

Fig. 5. Highly-affected population caused by electricity transmission.

transmission from the low/no scarcity basins, while the remaining 56% would still be exposed to the water scarcity problem even they were using electricity generated from lower water scarcity basins than they physically lived in.

3.4. Water scarcity mitigated or aggravated by the electricity transmission

From the perspective of population influenced by the electricity transmission, the water scarcity level of South China was aggravated as it had the largest affected population and the smallest benefited population among the 6 grids. While, the North, Northeast, East, and Central China mitigated their water scarcity risk by relocating the

electricity generation and transmission. Comparing the water stress imposed by the thermal power and hydropower, it is found that the hydropower was more effective in mitigating the water scarcity level owing to its significant contribution to the benefited population and little impact on the (highly-) affected population. Better allocation of the thermal power plants, especially in the southern part of China, would be desired to mitigate the water scarcity risk.

Attention should also be paid to the population who received electricity generated in the basins with the same water scarcity level as the places they physical lived in (see SI Table S12). This means they were making no improvement on relieving the water scarcity problem. Especially, nearly 66% of these people in the North China grid were

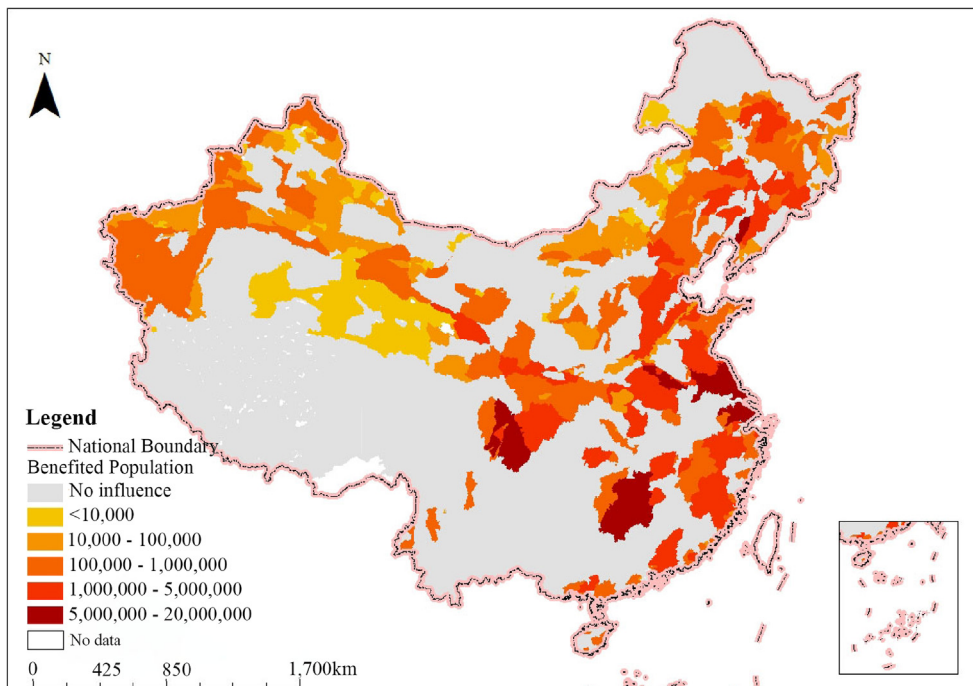

Fig. 6. Benefited population distribution.

living in basins with extreme scarcity. Given the fact of the distribution of water scarcity of the North China grid (see Fig. 2 and SI Fig. S3), the reallocation of power plants would have limited contribution to mitigate the water scarcity. Therefore, even though these places were abundant in coals [43], the vulnerability of thermal power to water scarcity [21,23] suggested the low possibility of installing new or re-allocating the thermal power plant there. Developing less water-intensive electricity, such as wind power [23,44], would be a more suitable solution. Moreover, the comprehensive evaluation of the long distance transmissions (e.g. “West to East Electricity Transmission” project and “North to South coal transportation” projects) from the water-energy nexus and the associated social impact would be needed.

4. Discussion

Previous studies showed that the contradiction between water endowment and thermal electricity in northern part of China when comparing with southern part of China [23,45,46]. This study quantifies this conflict at the basin level, a much higher spatial resolution. The results show that although the North China and Northeast China grids suffered more severe water scarcity, they were more capable to mitigate this conflict by locating their thermal power in less water stressed basins. It was also found that thermal electricity generation in the South China grid, which was usually regarded as being abundant in water, would cause pressure on local water resources as the status-quo. It was inconsistent electricity spatially distribution with the water resource. Moreover, when considering the cooling type for thermal electricity generation, the once-through cooling type in southern part of China would exacerbate local water scarcity [22].

Overall, the population relying on inter-grid transmission was estimated to be 609 million, accounting for 47% of national population. The highly-affected population, affected population and benefited population were 61, 134 and 249 million, respectively, accounting for 5%, 10% and 19% of the national total. If the monthly power plant's generation data and WSI data were available, these population would be even greater when adopting the calculation based on people living in water stressed places at least 1 month per year (0.9 billion in China [1]). This gave new insight into addressing the water scarcity issue: at least 12% more population should be regarded as being threatened by water scarcity, considering the fact that around 443 [11], 525 [12] or 661 million (this study) (34% or 38% or 50% of the national population) were living in severe/extreme water shortage regions.

The dataset in this study was an acceptable representative (the total electricity generation and the electricity generation structure (thermal/hydro power generation)) for most of the grids except for the Northwest China grid (detailed comparison was provided in SI Fig. S4 and Table S2). The mismatch between the dataset and statistics in the Northwest China grid might not have significant influence on the highly-affected population, as most of the basins there faced severe or extreme scarcity (see SI Fig.S3) and only 16% of its population were living in no/low stress basins (see SI Table S4). This mismatch could influence the absolute value of the affected/benefited population in Northwest China. Yet, considering the fact that its population were only 9% of the national total population, the affected/benefited population would not be significantly influenced at the national level.

This new understanding of water scarcity threatened population was estimated to be from the southern part of China, where were considered as water abundant on the basis of traditional understanding. This contrary distribution of the water stressed population under two understandings was validated in the similar research conducted in U.S. [9], in which the water abundant eastern U.S. was identified as exposed to additional water scarcity due to the electricity transmission. The affected population and benefited population were estimated to be 58 million and 72 million for U.S. for at least one month a year [9]. The contrast of these two kinds of population was less significant than that of China (i.e. 134 million and 249 million). However, this contrast was

less remarkable for the affected/benefited population caused by the thermal electricity transmission. This means that China made better effort in alleviating the water scarcity by the hydroelectricity than the thermal power. This is also true from the perspective of virtual water flows, i.e. China's major thermal power producing provinces in the west had the largest volumes of net virtual water outflows when all types of electricity generation were considered [19].

This study regards hydropower as less water-intensive than the thermal power. However, there are some arguments surrounding this issue. For example, evaporation during hydropower generation ranged significantly, depending on the study [47,48], and the other purposes (e.g. flood control, irrigation, etc.) of hydropower could influence the water-intensity accounting of electricity generation [49–51]. Besides, the ecological impact of hydropower [52] might be a major concern when considering the feasibility of building new dams. As such, the 6% of the hydropower generation in China, which was from basins with moderate to extreme water scarcity level (especially in Central China) (c.f. SI Table S3), might impose extra pressure on local water scarcity. The assumption in this study would be important in determining the fairness of the electricity generation structure of each grid.

5. Conclusion

Bringing up the concepts of (highly-) affected/benefited population due to thermal/hydro- electricity transmission gives insights into the social influence of electricity transmission within grids. This could help understand the relationship between water scarcity and electricity generation at the basin level.

In this study, we downscale the electricity consumption, grids, and water scarcity from the province or city level to the basin level, and aggregate the population and electricity generation from county level or plant level to basin level. From the perspective of the water scarcity structure of electricity generation, the North China, Northeast China, and Northwest China grids had better environmental performance because the power plants in these regions were in less water-stressed basins than their own water resource endowment. The results identify a number of basins which consumed their scant water resource to transmit thermal electricity to deficient basins in the North China, Northeast China, East China, South China, and Northwest China grids. As a result, 61 or 60 million people (4.6% or 4.5% of the national population) would be exposed to water scarcity due to electricity or thermal electricity transmission. These people were mostly based in the South China and Central China grids. However, the population who relied on electricity transmission was 10 times larger (609 million) and mainly came from the Central China grid. About 134 or 124 million people, accounting for 10.2% or 9.5% of the national population, were causing unfairness or worsening the water scarcity problem in basins with higher water scarcity level than themselves by electricity or thermal electricity transmission, most of which were living in the South China grid. On the other hand, there were 249 million or 161 million people benefited from the electricity or thermal electricity transmission. Based on our analysis, though the hydropower generated around 17% of the total electricity, thermal power was still the dominate driving force in terms of (highly-) affected population, and was worse in mitigating the water scarcity. Better allocation of the thermal power plants (especially in the southern part of China) with further consideration of the water endowment and electricity demand would contribute to the relief of water scarcity pressure.

A few further efforts would be desired. First, the more complete power plants dataset would lead the results to be more accurate by making up the missing electricity generation in some basins. Meanwhile, analyzing the freshwater withdrawal and consumption by distinguishing the cooling type and water resource of each power plant would give more detailed information about the conflict between electricity generation and water resources. Second, the mismatch of water scarcity indicators in 2011 and the dataset in 2014 could lead to

deviation of the results. Third, the uncertainty coming from the methods of re-scaling the various datasets from different levels to the basin level could lead to systematic errors. Besides, using the provincial per capital electricity consumption (due to data limitation) to estimate the high-resolution basin level electricity consumption would result in the deviation and uncertainty of the results. Fourth, the assumptions of the inter/intra-grid's electricity transmission could lead to a disturbance in the (highly-) affected/benefited population. Without access to detailed transmission data at city or basin level, the intra-grid's surplus electricity was considered to have to same possibility to the deficient basins. Though electricity transmission at the province level were available, the geographical mismatch of the provinces and basins and the incomplete cover rate of electricity generation of the dataset in this study still limited the usability of this province-based electricity transmission information. However, it could be inferred that the (highly-)affected population would be underestimated without consideration of the inter-grid electricity transmission. A basin-level input-output data for electricity transmission could be expected to carry out the accounting of electricity transmission between grids.

Acknowledgement

This work was supported by National Natural Science Foundation of China (No. 71774096).

Appendix A. Supplementary data

Supplementary data to this article can be found online at <https://doi.org/10.1016/j.apenergy.2019.01.120>.

References

- Mekonnen MM, Hoekstra AY. Four billion people facing severe water scarcity. *Sci Adv* 2016;2:e1500323.
- Kummu M, Guillaume JH, de Moel H, Eisner S, Florke M, Porkka M, et al. The world's road to water scarcity: shortage and stress in the 20th century and pathways towards sustainability. *Sci Rep* 2016;6:38495.
- Degefu DM, He WJ, Liao ZY, Yuan L, Huang ZW, An M. Mapping monthly water scarcity in global transboundary basins at country-basin mesh based spatial resolution. *Scientific Reports* 2018;8:(1).
- Wang R, Zimmerman J. Hybrid analysis of blue water consumption and water scarcity implications at the global, national, and basin levels in an increasingly globalized world. *Environ Sci Technol* 2016;50:5143–53.
- Liao X, Zhao X, Hall JW, Guan D. virtual water transfers through China's electric power sector. *Appl Energy* 2018;226:252–60.
- Han MY, Chen GQ, Li YL. Global water transfers embodied in international trade: tracking imbalanced and inefficient flows. *J Cleaner Prod* 2018;184:50–64.
- Qu S, Liang S, Konar M, Zhu ZQ, Chiu ASF, Jia XP, et al. Virtual water scarcity risk to the global trade system. *Environ Sci Technol* 2018;52:673–83.
- Tamea S, Laio F, Ridolfi L. Global effects of local food-production crises: a virtual water perspective. *Sci Rep* 2016;6:18803.
- Wang R, Zimmerman JB, Wang C, Font Vivanco D, Hertwich EG. Freshwater vulnerability beyond local water stress: heterogeneous effects of water-electricity nexus across the continental United States. *Environ Sci Technol* 2017;51:9899–910.
- Alcamo J, Henrichs T, Rosch T. Global modeling and scenario analysis for the World Commission on Water for the 21st Century. *Kassel World Water Series* 2000;2.
- Jiang Y. China's water scarcity. *J Environ Manage* 2009;90:3185–96.
- Satoh Y, Burek P, Wada Y, Florke M, Eisner S, Hanasaki N, et al. Asian water futures-multi scenarios, models and criteria assessment. *EGU General Assembly* 2016.
- Cai J, Varis O, Yin H. China's water resources vulnerability: a spatio-temporal analysis during 2003–2013. *J Cleaner Prod* 2017;142:2901–10.
- Shang YZ, Hei PF, Lu SB, Shang L, Li XF, Wei YP, et al. China's energy-water nexus: assessing water conservation synergies of the total coal consumption cap strategy until 2050. *Appl Energy* 2018;210:643–60.
- Li X, Chalvatzis KJ, Pappas D. Life cycle greenhouse gas emissions from power generation in China's provinces in 2020. *Appl Energy* 2018;223:93–102.
- Ministry of Environmental Protection. *China Environmental Statistics Annual Report*; 2015 (in Chinese).
- Zhang C, Anadon LD. A multi-regional input-output analysis of domestic virtual water trade and provincial water footprint in China. *Ecol Econ* 2014;100:159–72.
- Zhao X, Liu J, Liu Q, Tillotson MR, Guan D, Hubacek K. Physical and virtual water transfers for regional water stress alleviation in China. *Proc Natl Acad Sci USA* 2015;112:1031–5.
- Zhang C, Zhong L, Liang S, Sanders KT, Wang J, Xu M. Virtual scarce water embodied in inter-provincial electricity transmission in China. *Appl Energy* 2017;187:438–48.
- Shen W, Han W, Wallington TJ. Current and future greenhouse gas emissions associated with electricity generation in China: implications for electric vehicles. *Environ Sci Technol* 2014;48:7069–75.
- Zheng X, Wang C, Cai W, Kummu M, Varis O. The vulnerability of thermoelectric power generation to water scarcity in China: current status and future scenarios for power planning and climate change. *Appl Energy* 2016;171:444–55.
- Zhang C, Zhong L, Fu X, Wang J, Wu Z. Revealing water stress by the thermal power industry in China based on a high spatial resolution water withdrawal and consumption inventory. *Environ Sci Technol* 2016;50:1642–52.
- Feng K, Hubacek K, Siu YL, Li X. The energy and water nexus in Chinese electricity production: a hybrid life cycle analysis. *Renew Sustain Energy Rev* 2014;39:342–55.
- Zhu X, Guo R, Chen B, Zhang J, Hayat T, Alsaedi A. Embodiment of virtual water of power generation in the electric power system in China. *Appl Energy* 2015;151:345–54.
- National Bureau of Statistics, *China Statistical Yearbook*. Beijing, 2015 [in Chinese].
- WRI. *Aqueduct Global Maps 2.1 Data* < <http://www.wri.org/resources/data-sets/aqueduct-global-maps-21-data> > [accessed in August, 2018].
- Qu S, Liang S, Xu M. CO₂ emissions embodied in interprovincial electricity transmissions in China. *Environ Sci Technol* 2017;51:10893–902.
- China Electricity Council. *A list of coal-fired power plants larger than 100 MW with installed capacity*. Beijing 2015. (in Chinese).
- China Electricity Council. *Circulating-Fluidized-Bed-Boiler plants*. Beijing; 2015 [in Chinese].
- National Electricity Administration. *Statistical Yearbook of Electric Power*. Beijing; 2015 [in Chinese].
- Google. *Google Earth* < <https://www.google.com/earth/> > [accessed in August, 2018].
- Baidu. *Pickup Coordinate System*. < <http://api.map.baidu.com/lbsapi/getpoint/index.html> > [accessed in August, 2018] [in Chinese].
- Esri. *Arc GIS* < <https://www.arcgis.com/features/index.html> > [accessed in August, 2018].
- National Bureau of Statistics. *Energy Statistical Yearbook*. Beijing; 2015 [in Chinese].
- National Bureau of Statistics. *Tabulation on the 2010 population census of the People's Republic of China*. Beijing; 2010 [in Chinese].
- Xu S, Chen W. The reform of electricity power sector in the PR of China. *Energy Policy* 2006;34:2455–65.
- Liu R. *National Power Grid in China: the reform of electricity industry*; 2016 [in Chinese].
- Brown A, Matlock MD. *A review of water scarcity indices and methodologies*. University of Arkansas; 2011.
- Oki T, Agata Y, Kanae S, Saruhashi T, Yang D, Musiak K. Global assessment of current water resources using total runoff integrating pathways. *Hydrol Sci J* 2001;46:983–95.
- Hong JK, Shen QP, Xue F. A multi-regional structural path analysis of the energy supply chain in China's construction industry. *Energy Policy* 2016;92:56–68.
- Zhang C, Zhong L, Fu X, Zhao Z. Managing scarce water resources in China's coal power industry. *Environ Manage* 2016;57:1188–203.
- Mekonnen MM, Gerbens-Leenes PW, Hoekstra AY. Future electricity: the challenge of reducing both carbon and water footprint. *Sci Total Environ* 2016;569–570:1282–8.
- WRI. *Identifying the Global Coal Industry's Water Risks* < <http://www.wri.org/blog/2014/04/identifying-global-coal-industry%E2%80%99s-water-risks> > [accessed in August 2018].
- Sun S, Liu F, Xue S, Zeng M, Zeng F. Review on wind power development in China: current situation and improvement strategies to realize future development. *Renew Sustain Energy Rev* 2015;45:589–99.
- Cai B, Zhang B, Bi J, Zhang W. Energy's thirst for water in China. *Environ Sci Technol* 2014;48:11760–8.
- Jiang Y. China's water security: current status, emerging challenges and future prospects. *Environ Sci Policy* 2015;54:106–25.
- Mekonnen MM, Hoekstra AY. The blue water footprint of electricity from hydropower. *Hydrol Earth Syst Sci* 2012;16:179–87.
- Scherer L, Pfister S. Global water footprint assessment of hydropower. *Renew Energy* 2016;99:711–20.
- Grubert EA. Water consumption from hydroelectricity in the United States. *Adv Water Resour* 2016;96:88–94.
- Bakken TH, Modahl IS, Raadal HL, Bustos AA, Arnoy S. Allocation of water consumption in multipurpose reservoirs. *Water Policy* 2016;18:932–47.
- Lee U, Han J, Elgowainy A, Wang M. Regional water consumption for hydro and thermal electricity generation in the United States. *Appl Energy* 2018;210:661–72.
- Pang M, Zhang L, Ulgiati S, Wang C. Ecological impacts of small hydropower in China: insights from an energy analysis of a case plant. *Energy Policy* 2015;76:112–22.